

## Module and Application Description

Publication No.

D KWL 6316 93 E, Edition 08/96

Replacing D KWL 6316 93 E, Edition 07/94

## Station – Bus Coupling Module coupling a PROCONTROL station to the remote bus

### **88TK05 – E/R1210**

#### Application

This module is used in stations belonging to the PROCONTROL system.

In conjunction with remote – bus coupling module 88FT05, it is used for coupling a PROCONTROL station to the remote bus.

Moreover, the module controls all operations which are required to exchange data within a PROCONTROL station.

The connection of the station bus to the PROCONTROL remote bus may either be of single – channel or dual – channel design (cf. block diagram for 'Connecting the stations').

When installed in an autonomous station, the module performs the functions of a bus control module.

#### Features

The module is equipped with

- One standard interface (SS) with the station bus
- One RS485 interface with remote – bus coupling module 88FT05
- One module data interface with remote – bus coupling module 88FT05
- One potential – isolated monitoring interface
- One interface for dual – channel station – bus coupling
- One input for operating the transmitter output stages in remote – bus coupling module 88FT05.

The module uses module addresses 60 or 61 (depending on whether it is intended for single – channel or dual – channel mode) as well as module address 62 (cf. chapter on 'Setting the station, system and module addresses').

The module can be plugged into any slot of the PROCONTROL cabinet. In the standard cabinets, however, reserved slots are provided.

Error – free telegram transfer between the 88TK05 and older PROCONTROL modules located in the same station is ensured only if these modules have been manufactured after 1987 (serial nos. 9xx8 and higher).

#### Design of the module

The module essentially consists of the following functions:

- Remote bus coupling
- Control of the station protocol
- Setting the module, station and system addresses
- RS485 interface
- Module data interface
- Monitoring interface
- Interface for dual – channel station – bus coupling
- Diagnosis and annunciation functions

#### Remote bus coupling

##### **Sending data from the station**

For sending data communication, two main modes are available which are controlled by the communication controller:

- Cyclic mode
- Event mode.

In the cyclic mode, the communication controller polls the stations one by one. This call for sending data telegrams is evaluated by the 88TK05 and is forwarded to the station.

In event mode, the 88TK05 signals the presence of events in the station by activating the noise channel. Then, the communication controller identifies the requesting station and generates an event call, which is evaluated by the 88TK05, and forwards it to the station.

The 88TK05 sends the cyclic or event telegrams provided by the station modules after polling. Transmission is via the 88FT05 to the remote bus.

All telegrams are checked for formal correctness and accurate contents. If an error is detected, the telegram is retained, and the 88TK05 sends a diagnosis telegram instead.

Until the next call, the 88TK05 module buffers each block of telegrams sent from the station for repeated transmission, in case the communication controller would receive an erroneous telegram or if a sent telegram does not arrive at all.

## Sending data to the station

The module receives all telegrams transmitted over the PROCONTROL remote bus and checks them for formal correctness and accurate contents.

A distinction is made between send–location–addressed telegrams and destination–addressed telegrams. Send–location–addressed telegrams are checked for formal accuracy and, if found to be correct, sent to the station.

Destination–addressed telegrams are checked for formal accuracy and correct contents and are sent to the station only if the system and station addresses match.

Formal accuracy is checked on the basis of control characters protecting the telegram contents such as operation code, addresses, and data (hamming distance: 6).

Over the PROCONTROL bus system, certain destination–addressed telegrams can be transferred which are intended exclusively for the station–bus coupling module. These telegrams are mainly used for controlling remote–bus coupling module 88FT05. These telegrams are identified by comparing the addresses (station, system, module), but are not forwarded to the station bus.

If an error is detected in telegrams destined for the station, these telegrams will not be sent to the station. Instead, the module puts out a signal over the noise channel in order to cause the communication controller to send the telegrams in question one more time.

## Control of the station protocol

### Station–bus communication

Data communication with the station follows a defined protocol which is controlled by the 88TK05.

All PROCONTROL station modules follow this protocol, i.e. no module of the station may actively participate in data transfer without a permission.

Protocol control mainly comprises the following functions:

- Identifying those modules which request a permit for sending data telegrams to the station bus,
- Granting a sending permit for one station module at a time for sending data telegrams to the station bus,
- Enabling or disabling a sent or received data telegram after it has been checked for proper contents and formal accuracy,
- Controlling cyclic mode within the station:  
In cyclic mode, all modules belonging to one station are granted – one by one – a permit to send their cyclic data starting with the highest module address. The send permit is effective until all data have been sent.

- Controlling the event mode in a station:

In event mode, each station module which has put out an event message is allowed to send a data telegram. Transmission begins with the highest module address.

Then, all modules indicating events are permitted, in descending order, to send a data telegram. This procedure is repeated until there are no more event messages to be sent (rotating priority).

- Controlling the list mode in a station:

For transmission of large amounts of data, list transmission is used. Depending on the type of list transmission (writing/reading), list master or list slave are granted the permit to send a telegram block with list data. List transmission is performed in cyclic mode.

- Receive mode:

When a data telegram for the station is received from the remote bus, cyclic mode as well as event mode will be interrupted in this station, and the station–bus coupling module is granted access to the bus for sending the receive telegram.

- Autonomous mode:

The autonomous mode is selected automatically, when no remote–bus connection is available or if no telegram has been received from the remote bus for more than 100 msec. The autonomous mode ends with the first telegram received from the remote bus.

In the autonomous mode, all necessary calls are generated by the station–bus coupling module, thus, assuming the control function of the communication controller within this station.

- Telegram monitoring:

Each telegram contains a number of control characters (hamming distance = 6) which are used to protect the telegram contents (operation code, addresses, data). The station–bus coupling module listens–in on all telegrams sent over the station bus and uses the control characters to check whether an error is present. In case an error has been detected, the module inhibits the telegram concerned. If no error is found, it will generate an enable signal. Only after this enable signal is present, a telegram may be sent from the station to the PROCONTROL bus system or be processed further by the output and processing modules of the station.

These control procedures ensure that only one module at a time sends data onto the serial station bus, thus, guaranteeing error–free data exchange within the station and to the remote bus.

### Address transmission

On the 88TK05, the respective system and station addresses of a PROCONTROL station are set. The 88TK05 sends this address information to the station bus in the form of a special telegram when the station is being initialized as well as once per system cycle on the station bus. This way, all modules of one PROCONTROL station are given the same station and system addresses set on the 88TK05.

## Setting the station, system and module addresses and the operating mode

On module 88TK05, the station and system addresses, the module addresses 60 or 61 and the modes of operation are set. Module address 62 is set automatically. For setting, 2 switches are available on the module (S1 and S2).

Switch S1 is used for setting the station address (STA):

Switch S1:

Assignments S1	STA							
Contacts S1	1	2	3	4	5	6	7	8
Significance	1	2	4	8	16	32	64	128

Example	ON							
	STA 129		•	•	•	•	•	•

Switch S2 is used for setting module addresses (GA) 60 or 61, system address (SYS) 0, 1, 2 or 3, the mode (BA) for 'autonomous station' (AS) or 'remote bus' (FB) as well as for activation or deactivation of 'module detection' (GE, i.e. function detecting which PROCONTROL station modules are plugged-in or removed).

Switch S2:

Assignments S2	GA	BA	GE	Not used			SYS	
Contacts S2	1	2	3	4	5	6	7	8
Significance							1	2

Example	ON							
	GA60		•					

Example	ON							
	GA61		•		•	•	•	

Example	ON							
	SYS01				•	•	•	•

Example	ON							
	BA AS			•				

Example	ON							
	BA FB			•	•	•	•	

Example	ON							
	BA GE active			•	•	•	•	

Contacts, which have not been assigned, must be set to 'Not ON'.

In the case of single-channel station coupling, module address 60 must be selected.

In the case of dual-channel station coupling, attention is to be paid to the fact that on the two 88TK05 modules the same station addresses, system addresses and operating modes, however, different module addresses (60, 61) need to be set.

For use in a distributed system (with remote bus), contact S2/2 has to be switched to position 'Not ON'.

The set station and system addresses are transmitted per telegram to all modules of the PROCONTROL station (cf. section on 'Control of the station protocol / address transmission').

Faulty settings of switches S1 and S2 cause error messages 'Operating mode setting wrong' (62/246/ bit 7) in single-channel mode or 'Partner module fault' (62/246/ bit 11) in dual-channel mode as well as permanent activation of LED ST.

The exact cause of the fault can be determined by reading background diagnosis registers 235 and 231 (cf. Figure 3 and 4).

## RS485 interface

This interface is used to condition and adapt the signals sent to remote-bus coupling module 88FT05.

All signals of this interface are transferred with their true and inverted value.

This RS485 interface handles the following signals:

- SE1+, SE1– Control of telegram sender and sender monitoring, remote-bus channel A On
- SE2+, SE2– Control of telegram sender and sender monitoring, remote-bus channel B On
- RE+, RE– Noise transmitter On
- DA+, DA– Telegram data
- RA+, RA– Telegram frame
- TA+, TA– Telegram clock pulse
- SP+, SP– Checkback signal of the transmission level of the active remote-bus channel
- RP+, RP– Checkback signal of the noise level of the active remote bus-channel
- FS+, FS– Signal for 'Remote-bus coupling fault' as a general disturbance signal of the 88FT05 to the RS485 interface
- ESP+, ESP– Disconnect signals for the 24 V supply of the telegram and noise transmitter output stages
- ANB+, ANB– Signal for 'Active remote-bus channel' (channel A = 1, channel B = 0)
- SGD, SGD Reference conductor, interface RS485
- US, US +24 V for 88FT05
- Z, Z Reference conductor for +24 V

## Module data interface

This interface is used to transfer module identification data to remote-bus coupling module 88FT05.

When several 88TK05 modules are used with one 88FT05 remote-bus coupling module, this interface must be connected to the first 88TK05 station-bus coupling module only.

## Monitoring interface

This module uses three potential–isolated signal inputs G12, G22 and G32 to which the external disturbance signals can be connected. A 89NU01 monitoring module can be connected to the potential–isolated binary signal output MST.

Input G12 uses the closed–circuit principle for monitoring the cabinet power supply. This function detects, whether a voltage supply for the station modules has failed. When the 88TK05 is operated without an 89NU01, this input needs to be connected externally. For this purpose, contacts b08/d08 and d06/z06 of connector X21 have to be connected (for assignments cf. 'Function diagram').

Input G22 uses the open–circuit principle and is provided for cabinet temperature monitoring.

Input G32 uses the open–circuit principle. It can be used for example for door monitoring if provided.

These three signals are put out for instance by the 89NU01 monitoring module (cf. Figure 1).

If any of these disturbance signals are present, an entry is made into the diagnosis register, and the cabinet lamp is activated via output MST and module 89NU01.

## Interface for dual–channel station–bus coupling

Module 88TK05 is equipped with an interface which allows dual–channel coupling between a station and the remote bus.

Using a 15–pole cable, the interface for dual–channel station–bus coupling is connected via the front panel with the respective interface of the partner module (cf. 'Function diagram').

The interface for dual–channel station–bus coupling handles the following signals:

PAKTN	Input signal 'Station–bus coupling partner module active on the remote bus'
KONFIG	Dual–channel station–bus coupling to remote bus available
SDO	Send data line for partner communication
ST	Send clock pulse line for partner communication
GSAO	Control of sending module OFF
KGAKTN	Output signal 'Station–bus coupling module active on the remote bus'
SDI	Receive data line for partner communication
ET	Receive clock pulse line for partner communication
GSAI	Control input of sending module transmitter OFF

In the case of dual–channel station–bus coupling, both 88TK05 modules alternately control protocol execution and data exchange within the station as well as data exchange with the remote bus.

After two complete system cycles, the active module changes over to the partner module which has been in the passive state so far.

In addition to the self–diagnosis functions, in its active phase, the active module is also monitored by the passive partner module for proper functioning.

For this purpose, the interface for dual–channel station–bus coupling is used for cyclic data exchange between the redundant modules in order to ensure that both modules are operable.

Mainly the following criteria are monitored:

- Proper functioning of the interface for dual–channel station–bus coupling
- Response of the watchdog function of a module
- Failure of bus protocol communication within the station
- Failure of data communication on the station bus
- System and station addresses of both partner modules are identical.

If a malfunction is detected, the partner module will switch off the bus driver of the defective module.

The disconnected module has to be exchanged to reestablish dual–channel communication.

The fault condition is signalled to the system by an entry into the diagnosis register of the active module and is also indicated by LEDs ST (red) and SG (red) on the front panel of the defective module.

## 88TK05 – Replacing modules with dual–channel station coupling

Bumpless replacement of 88TK05 modules with dual–channel station coupling is possible even while the module is on–line, without causing any disruption in the operation of the station concerned.

For this purpose, the interfaces for dual–channel station coupling need to be disconnected by pulling the connector on the module front. The modules can then be exchanged.

It is not admissible, to pull out an 88TK05 before the front–panel connector has been removed, nor is it admissible to connect the front–panel connector before the 88TK05 module is installed.

Non–compliance with these instructions may result in the failure of the entire station.

## Diagnosis and annunciation functions

### Disturbance annunciation signals to the annunciation system

The annunciation system and/or the control diagnosis system (CDS) receives disturbance signals from the module via the PROCONTROL bus.

They also include all disturbances detected by the sender monitoring functions on the 88FT05 remote-bus coupling module as well as the 'Group malfunction station detected' message generated from the single signals of the station modules.

The 88TK05 transfers its disturbance signals and diagnosis results in 2 diagnosis registers with register address 246.

Seven additional background diagnosis registers with register addresses 225, 227, 228, 231, 232, 235 and 237 are used for fault localization. They send only upon request under module address 60 or 61. For a description of the registers cf. Figures 3 through 6.

The contents of both diagnosis registers with register address 246 is transferred to the remote bus at the beginning of each cyclic call addressed to the PROCONTROL station.

Order of transmission:

- Diagnosis register under module address 60  
in the case of single-channel station-bus coupling or  
diagnosis register under module address 60 or 61  
in the case of dual-channel station-bus coupling
- Diagnosis register under module address 62

In event mode, each time the station is called for the first time, merely the diagnosis register under module address 60 (single-channel mode) or the diagnosis register under module address 60 or 61 (dual-channel mode) will be transferred to the remote bus as the first data telegram.

The following types of disturbances are detected:

1. Internal disturbances of the module
2. Disturbances in data communication on the station and the remote bus
3. Disturbance signals from other modules of the station (as 'Group malfunction station detected')
4. Disturbance signals from remote-bus coupling module 88FT05
5. Disturbance signals from the monitoring interface

All types of disturbances (1 ... 5) lead to an activation of binary signal output MST.

The disturbances type (1 ... 4) are indicated on the module front (cf. chapter on 'Disturbance annunciations on the module').

As an option, disturbance type 5 is indicated by the 89NU01 by activation of the cabinet lamp.

The contents of the diagnosis registers, the signals on the general disturbance line, the annunciations on the CDS, and indications ST and SG are shown in Figures 1 ... 5.

### Disturbance annunciations on the module

On the module front, the following disturbances are indicated by means of red LEDs:

	Designation of the LED
– General disturbance Disturbance types 1 ... 4	ST
– Disturbance of module 88TK05 Disturbance type 1	SG
– Disturbance of transmission path 88TK05/88FT05 Disturbance type 4	SG1
– Acknowledgement error Disturbance type 2 (only remote bus)	QF

Light-emitting diode ST indicates all disturbances of the module as well as disturbances in the data communication with the module. After three communication controller cycles without any disturbance, light-emitting diode ST will go off again. Additionally, ST is on for approx. 3 sec during initialization of the module or when the 88TK05 has disconnected a disturbed module from the station bus.

Light-emitting diode SG indicates module disturbances only. SG is also illuminated during initialization of the module for approx. 3 sec.

Light-emitting diode SG1 indicates disturbances of the transmission path on the data channel and noise channel.

Light-emitting diode QF indicates erroneous telegrams received from the remote bus. For this purpose, the error pulse is prolonged to approx. 100 msec.

### Status annunciations on the module

On the front panel, green LEDs indicate the following operating states:

	Designation of the LED
– Sends telegram to the remote bus	FS
– Receives telegram from the remote bus	FE
– Station-bus communication	SV
– Station-bus modules with events	ER

Light-emitting diode FS is illuminated, when telegrams are sent from the 88TK05 or the station bus to the remote bus.

Light-emitting diode FE is illuminated, when telegrams are sent from the remote bus to the station bus.

Light-emitting diode SV is illuminated, when telegrams are sent from the station bus to the remote bus.

Light-emitting diode ER is illuminated from the time of detection of an event until the event telegram has been transmitted.

### Receive monitoring on the 88TK05 and the 88FT05

The receive monitoring function on the 88FT05 monitors telegram reception for character distortion.

When the receive monitoring function responds, transmission of frame, data and clock pulse (RA, DA, TA) from the 88FT05 to the 88TK05 over the RS485 interface is interrupted until the next valid SYN character is received.

As a result, the abortion detector of the receive monitoring on the 88TK05 responds. The 88TK05 indicates the disturbance by entry 'Remote bus acknowledgement error' (bit 8) in its diagnosis register (GA60/61), and LED QF on the front of the module will be activated.

### Sender monitoring on the 88TK05 and the 88FT05

Station-bus coupling module 88TK05, which controls telegram sender and noise transmitter on the 88FT05, also monitors the telegram sender of the active remote bus-channel for absence of the transmission level and for excessively long send telegrams, i.e. telegram frames over 63  $\mu$ sec. It also monitors the noise transmitter of the active remote bus-channel for absence of the noise level.

The sender monitoring function on the 88FT05 monitors the telegram sender of the active remote-bus channel for excessively long telegram sending, i.e. sending of more than 64 telegrams without any interruption by reception of a complete telegram. It also monitors the noise transmitter of the active remote bus-channel for an excessively long noise signal, i.e. the noise transmitters are interrupted for more than 10 msec.

In the case of excessively long send telegrams, excessively long telegram sending or an excessively long noise signal, the drivers of the disturbed telegram sender are permanently switched off on the 88FT05 by means of signals SE1 or SE2 until the end of the cycle is reached.

The drivers are reconnected by the 88TK05 via signals SE1 or SE2 after the telegram for 'Start cycle communication controller' has been reached.

If the sender monitoring function for the telegram sender has responded three times in a row, the drivers of the disturbed telegram sender will be switched off.

Each one of the disturbances mentioned above will be indicated by entry 'Transmit path fault' (bit 9) into the diagnosis register (GA60/61) of the 88TK05.

### Monitoring of the module arrangement in a PROCONTROL station

In order to ensure fast detection of changes in the station's module arrangement due to removal or insertion of any module, the 88TK05 scans the modules at time intervals of < 3 msec over the module's internal parallel bus. The module arrangement identified in this way is then compared to the previous module data. If the same module changes have been detected three times, diagnosis message 'Station module arrangement changed' will be generated in the diagnosis register of GA 62 (cf. Figure 2). This message is transferred to the PROCONTROL system and is cancelled again > 1 sec after occurrence of the disturbance.

This monitoring function is available with software versions P0004 and higher of the 88TK05. It is effective only with the new PROCONTROL modules using a redundant 24 V supply.

Figure 1. 88TK05 diagnosis messages for module addresses 60, 61

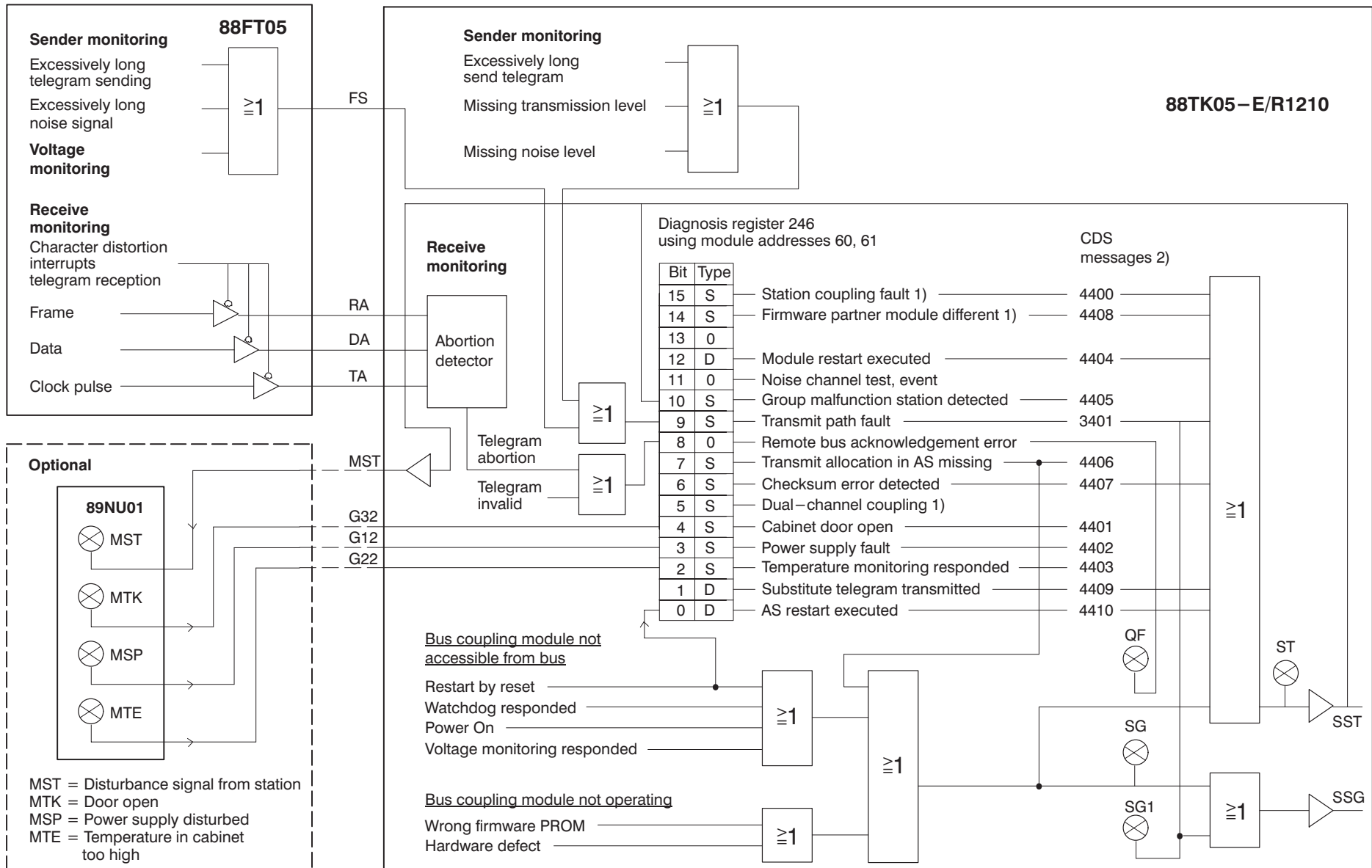

S = Static annunciations disappear automatically upon deactivation  
 D = Dynamic annunciations are cancelled after the contents of the diagnosis register has been transmitted  
 0 = Not used

1) Only with dual-channel station-bus coupling

2) The control diagnosis station provides a description for every message number.  
 This description includes:  
 - Information about cause and effect of the disturbance  
 - Recommendations for elimination  
 Thus, fast disturbance elimination is ensured.

**Module operating**

Diagnosis register 246  
using module address 62

Bit	Type		CDS messages
15	S	Module address code (A = 0 = 60, B = 1 = 61)	
14	S	Signal simulated	4430
13	D	Protocol error AS detected ①	4412
12	S	Channel code, 0 = single-channel, 1 = dual-channel	
11	S	Partner module fault ②	4424
10	0		
9	D	Module restart executed	4415
8	S	Module from AS bus disconnected ①	4416
7	S	Operating mode setting wrong ②	4423
6	S	Checksum error detected	4419
5	S	Station mod. arrangem. changed	4425
4	D	Telegram error in AS detected ①	4417
3	D	Cycle abortion detected ①	4428
2	D	Protocol error remote bus detected	4427
1	D	Response from module missing ①	4418
0	0		

**Module not accessible from bus**

Watchdog responded  
Power On  
Voltage monitoring responded

**Module not operating**

Wrong firmware PROM  
Hardware defect

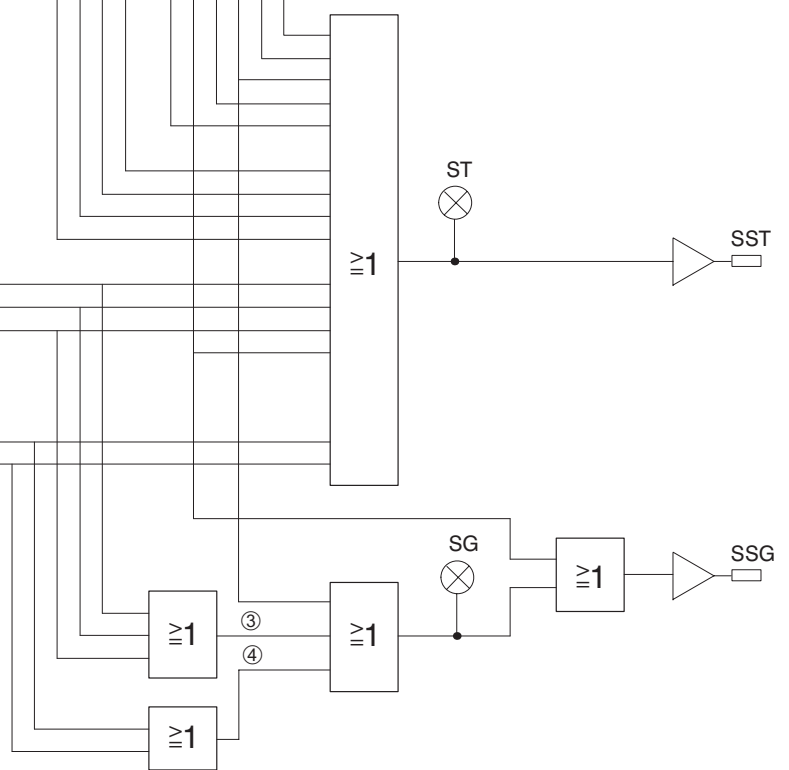

S = Static annunciations disappear automatically upon deactivation  
D = Dynamic annunciations are cancelled after the contents of the diagnosis register has been transmitted  
0 = Not used

- ① = For cause and associated module address cf. background diagnosis register, Figures 3 through 6
- ② = For cause cf. background diagnosis register, Figures 3 through 6
- ③ = Also causes the output of CDS message 'AS restart executed' ——— 4410
- ④ = Also causes the output of CDS message 'Response from AS missing' ——— 4204

Figure 2: 88TK05 diagnosis messages for module address 62

Background  
diagnosis register 225

**Cause for 'Response from module missing' (62/246/1)**

Bit	Type
15	0
14	0
13	0
12	0
11	0
10	0
9	0
8	0
7	D
6	D
5	D
4	D
3	D
2	D
1	D
0	D

} Module address (decimal) of the last permit

Background  
diagnosis register 227

**Cause for 'Cycle abortion detected' (62/246/3)**

Bit	Type
15	D
14	D
13	D
12	D
11	D
10	D
9	D
8	D
7	D
6	D
5	D
4	D
3	D
2	D
1	D
0	D

} Counter for number of cycle abortions

} Module address (decimal) of the module  
which fails to respond after being granted two permits

D = Dynamic annunciations are cancelled after the contents of the diagnosis register has been transmitted  
0 = Not used

Figure 3: Background diagnosis registers 225 and 227.

Background  
diagnosis register 228

**Cause for 'Telegram error in AS detected' (62/246/4)**

Bit	Type
15	D
14	D
13	D
12	D
11	D
10	D
9	D
8	D
7	D
6	D
5	D
4	D
3	D
2	D
1	D
0	D

Counter for number of telegram errors

Module address (decimal) of the last permit

Background  
diagnosis register 231

**Cause for 'Operating mode setting wrong' (62/246/7)**

Bit	Type
15	0
14	0
13	0
12	0
11	0
10	0
9	0
8	0
7	0
6	0
5	0
4	D
3	D
2	D
1	0
0	0

No cyclic call 1.8

Different P version of the firmware PROMs

Autonomous station, remote bus reception

D = Dynamic annunciations are cancelled after the contents of the diagnosis register has been transmitted  
0 = Not used

Figure 4: Background diagnosis registers 228 and 231.

Background  
diagnosis register 232

**Cause for 'Module from AS bus disconnected' (62/246/8)**

Bit	Type
15	0
14	0
13	0
12	0
11	0
10	0
9	0
8	0
7	D
6	D
5	D
4	D
3	D
2	D
1	D
0	D

} Module address (decimal) of the disconnected module

Background  
diagnosis register 235

**Cause for 'Partner module fault' (62/246/11)**

Bit	Type
15	0
14	0
13	0
12	0
11	0
10	0
9	0
8	0
7	0
6	0
5	0
4	S
3	S
2	S
1	S
0	S

— Different operating mode  
 — 88FT05 defective  
 — Hardware defect / interface for dual-channel station coupling removed  
 — Wrong station/system address setting  
 — Wrong module address setting 60, 61

S = Static annunciations disappear automatically upon deactivation

D = Dynamic annunciations are cancelled after the contents of the diagnosis register has been transmitted

0 = Not used

Figure 5: Background diagnosis registers 232 and 235.

Background  
diagnosis register 237

**Cause for 'Protocol error AS detected' (62/246/13)**

Bit	Type	
15	0	
14	0	
13	0	
12	0	
11	0	
10	0	
9	D	Telegram contents not plausible
8	D	Protocol violation
7	D	} Module address (decimal) of the last permit
6	D	
5	D	
4	D	
3	D	
2	D	
1	D	
0	D	

D = Dynamic annunciations are cancelled after the contents of the diagnosis register has been transmitted  
0 = Not used

Figure 6: Background diagnosis register 237.

## Function diagram

### Terminal designations

The printed-circuit board includes connectors X1, X11 and X21. Connector X1 contains the interface for dual-channel station-bus coupling.

Connector X11 contains the standard interface for the station bus.

Connector X21 contains the RS485 interface, the module data interface for remote-bus coupling module 88FT05, the voltage supply US for the 88FT05 and the interface with monitoring and flasher module 89NU01.

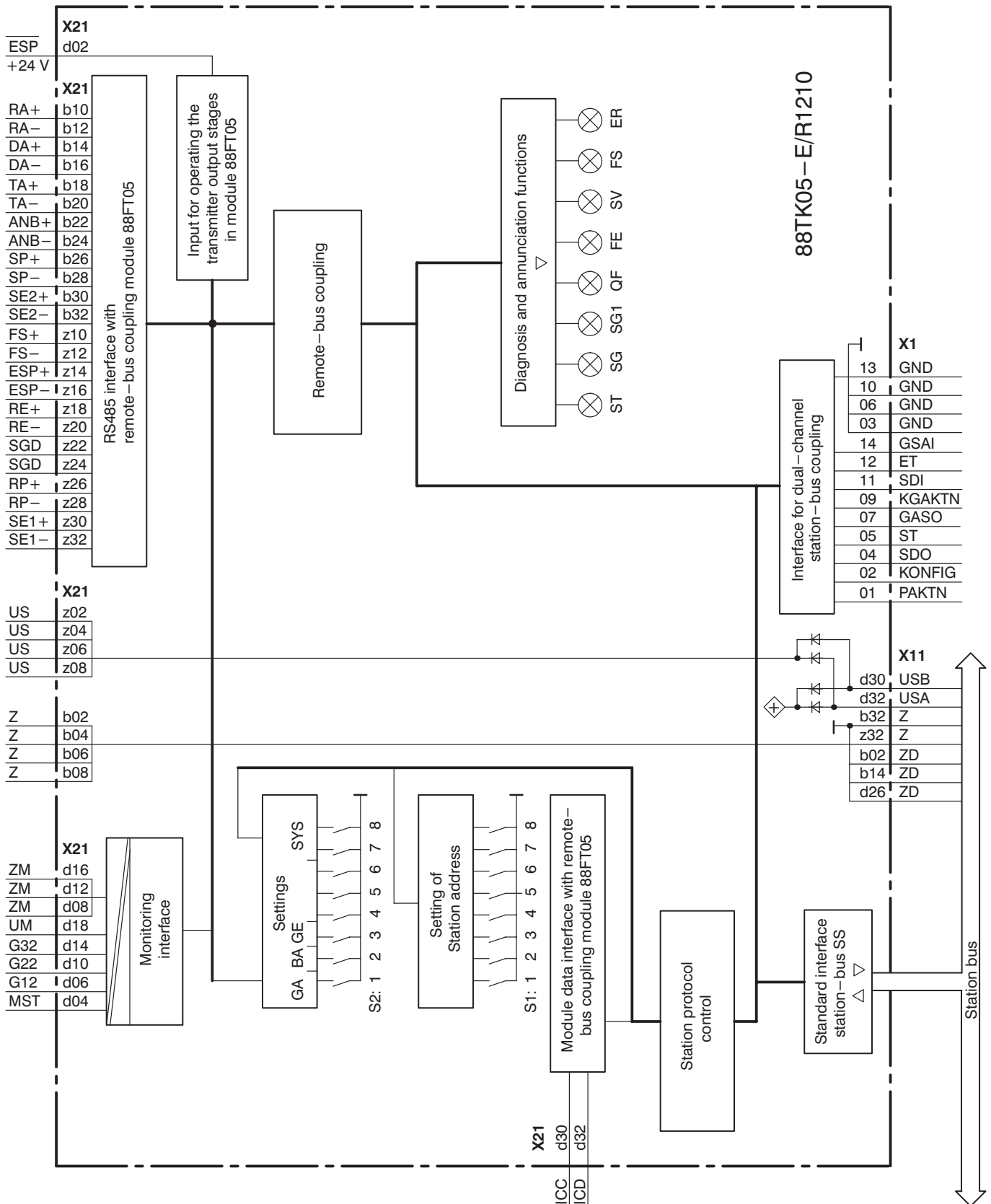

## Block diagram 'Connection of the stations'

### Single-channel station-bus coupling

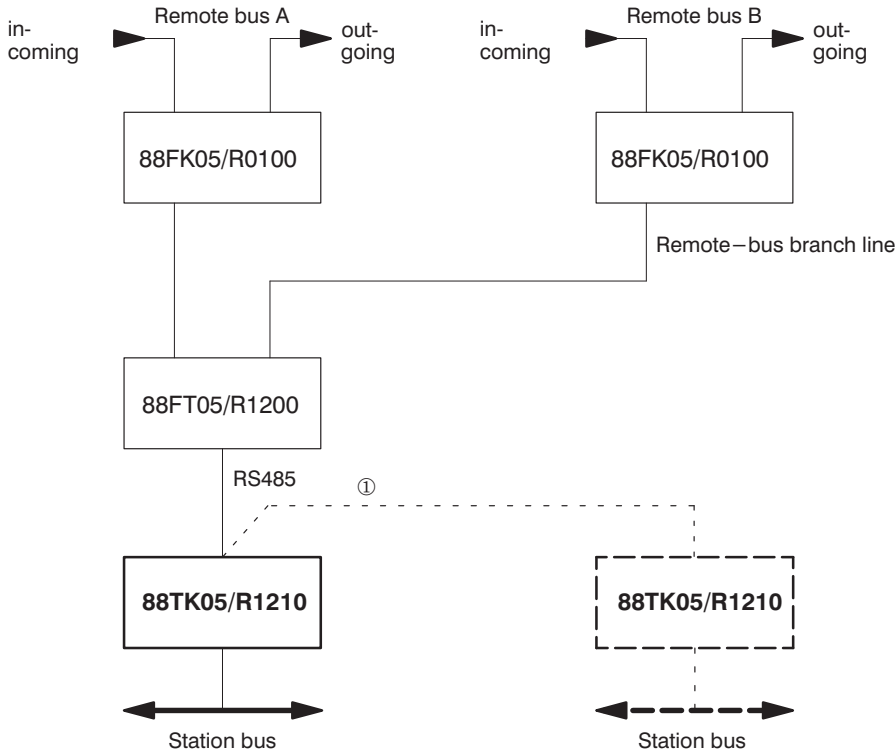

### Dual-channel station-bus coupling

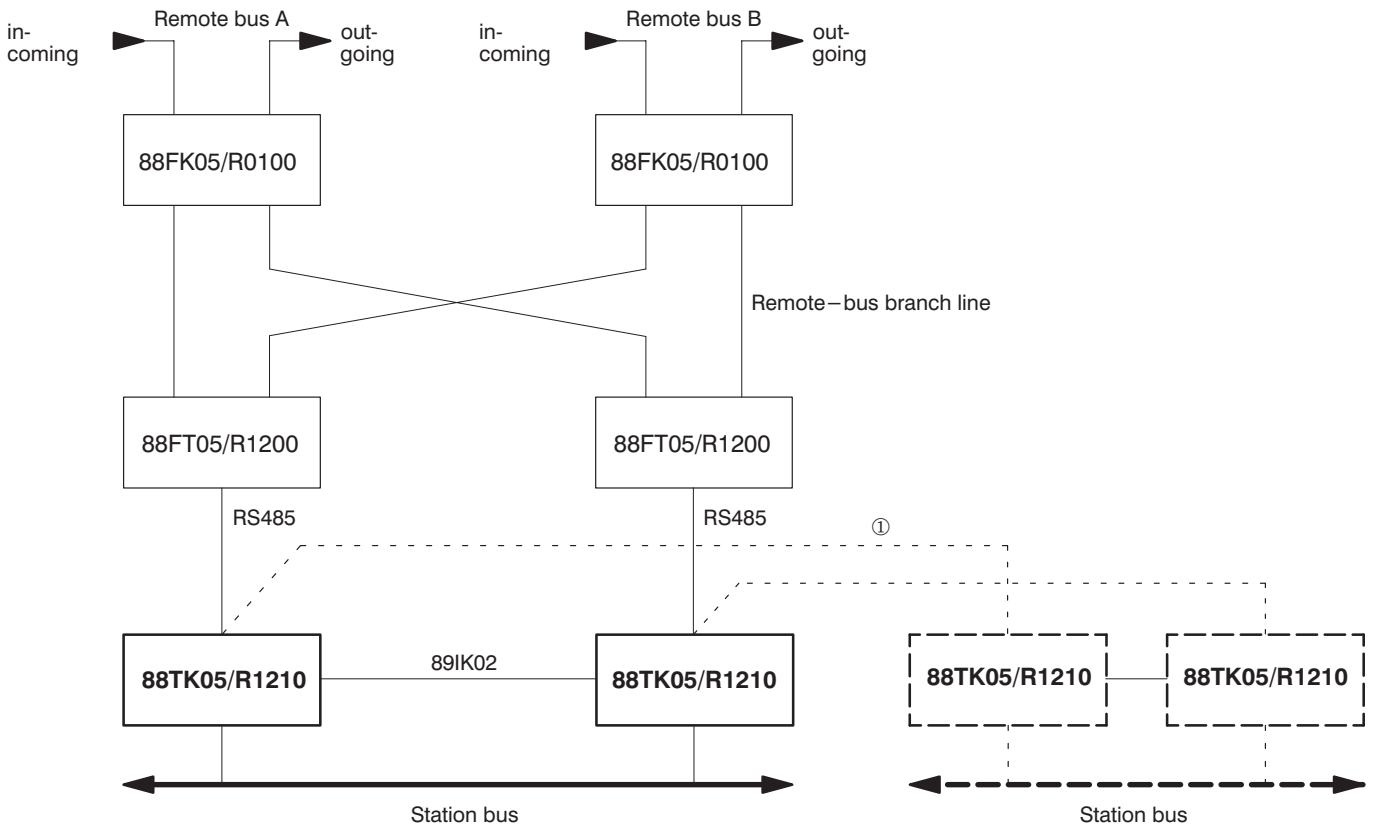

① Max. four stations can be connected in adjacent cabinets.

## Mechanical design

Board size: 6 units, 1 division, 160 mm deep  
 Connector: X11, X21 to DIN 41612  
 2 x 48-pole edge connector, type F  
 X1 to MIL-C-24308  
 1 x 15-pole jack connector, type HDP 20  
 Weight: approx. 0.5 kg

View of connector side:



## Contact assignments of connector X21

View of contact side:

	<i>d</i>	<i>b</i>	<i>z</i>
02	ESP	Z	US
04	MST	Z	US
06	G12	Z	US
08	ZM	Z	US
10	G22	RA+	FS+
12	ZM	RA-	FS-
14	G32	DA+	ESP+
16	ZM	DA-	ESP-
18	UM	TA+	RE+
20		TA-	RE-
22		ANB+	SGD+
24		ANB-	SGD-
26		SP+	RP+
28		SP-	RP-
30	ICC	SE2+	SE1+
32	ICD	SE2-	SE1-

## Contact assignments of connector X1

View of contact side:

01	PAKTN
02	KONFIG
03	GND
04	SDO
05	ST
06	GND
07	GSAO
08	
09	KGAKTN
10	GND
11	SDI
12	ET
13	GND
14	GSAI
15	

View of module front and module side

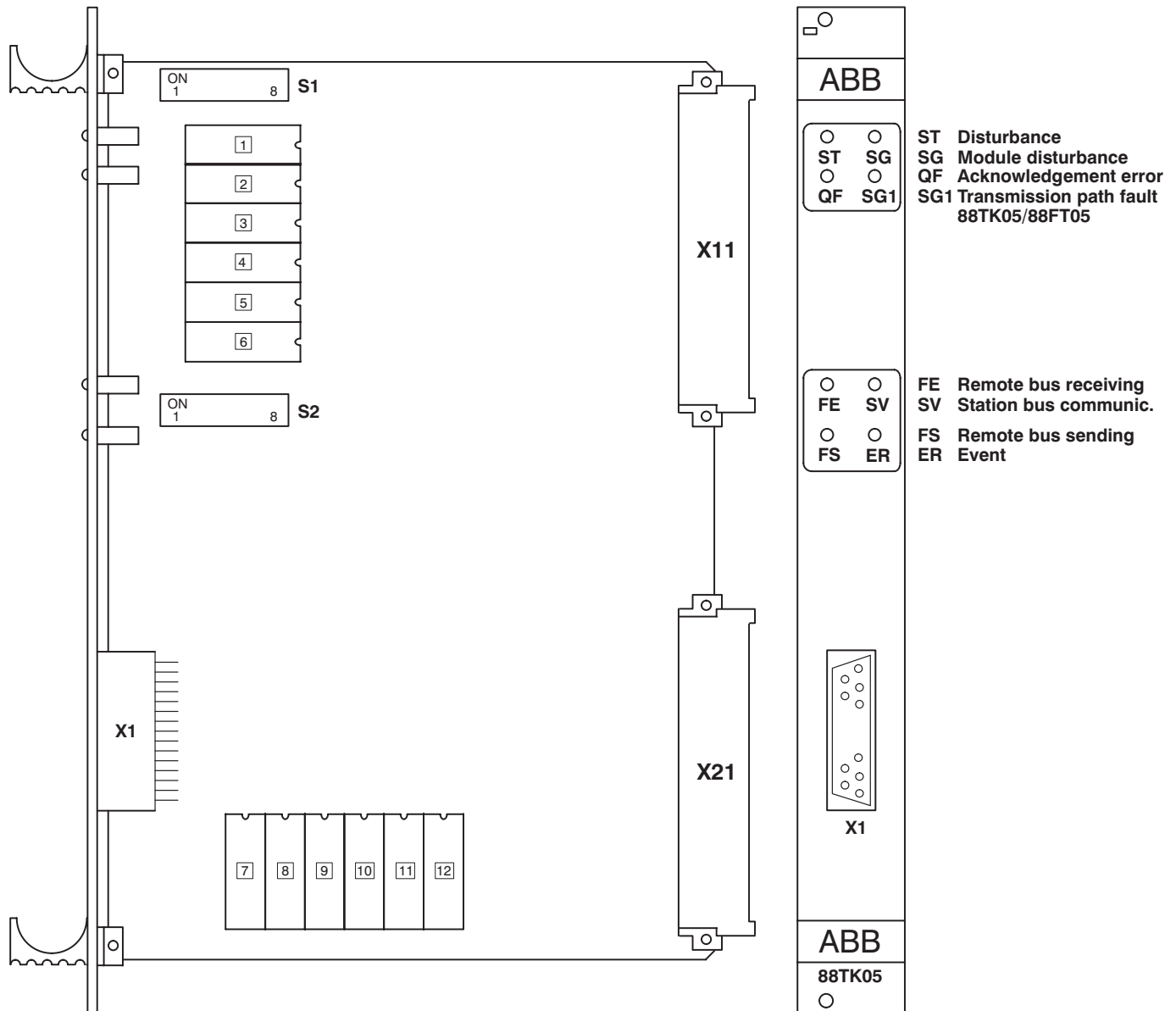

Memory modules:

Order numbers:  
(EPROM programmed)

1	= A101	GJR2393241Pxxxx
2	= A102	GJR2393242Pxxxx
3	= A103	GJR2393243Pxxxx
4	= A104	GJR2393244Pxxxx
5	= A105	GJR2393245Pxxxx
6	= A106	GJR2393246Pxxxx
7	= A401	GJR2393247Pxxxx
8	= A402	GJR2393248Pxxxx
9	= A403	GJR2393249Pxxxx
10	= A404	GJR2393250Pxxxx
11	= A405	GJR2393251Pxxxx
12	= A406	GJR2393252Pxxxx

Remarks on PROMs:

Under the order no. for the complete module, the complete set of memory modules required for the basic program is included in the delivery.

Note:

The number also indicates the position on the printed-circuit board.

xxxx = Position number indicating the applicable program version.

## Technical data

In addition to the system data, the following values apply:

### Power supply (on the module)

Operating voltage	24 V +/- 25 %
Current consumption IS for approx.	166 mA
Power dissipation, typical	4 W

### Monitoring interface

#### Input values

G12 – Disturbance of cabinet voltage supply The input uses the closed-circuit principle	le = 5 mA Ue = 24 V
G22 – Thermostat responded	le = 5 mA Ue = 24 V
G32 – Cabinet door open	le = 5 mA Ue = 24 V
UM – Annunciation voltage	UM = 24 V

#### Output values

MST – General station disturbance	la = 6 mA Ua = 24 V
-----------------------------------	------------------------

### RS485 interface for remote-bus coupling module 88FT05

RS485 standard	
Transmission rate	1 Mbaud
Termination resistor	100 ohms
Passive differential signal voltage	400 mV
Max. length of the connection between 88TK05/88TK05	10 m (total) type of cable RD-Y (ST) Y 16 x 2 x 0.22 mm or standard wiring
Max. length of the connection between 88TK05/88FT05	1 m, cable 89IK01
Max. number of stations in max. 2 mechanically interconnected cabinets	4
Input ESP	le = 5 mA Ue = 24 V

### Interference immunity (of station-bus coupling)

in case of proper installation

ESD acc. to IEC 801/2	8 kV to front panel
EMC acc. to IEC 801/4	2 kV burst included in remote bus cable

## ORDERING DATA

Order no. for complete module:

Type designation: 88TK05-E/R1210

Order no.: GJR2393200R1210

Accessories:

89IK02 cable for dual-channel station-bus coupling

Order no.: GKWE 602380R0090

Technical data are subject to change without notice!



---

ABB Kraftwerksleittechnik GmbH

P. O. Box 100351, D-68128 Mannheim  
Phone (0621) 381 2712, Telefax (0621) 381 4372  
Telex 462 411 107 ab d

Printed in Germany (PPC/R11 1197 0,3 BSD)